

REV	ECN.NO:	BY	DATE
A0	NEW DWG	Joe Chen	11.11.18

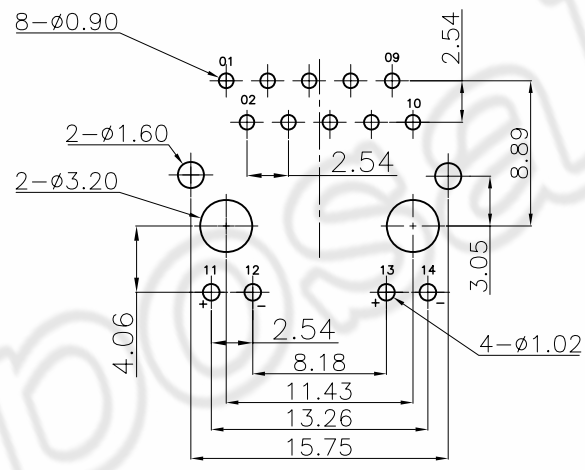

PCB LAYOUT
TOP VIEW

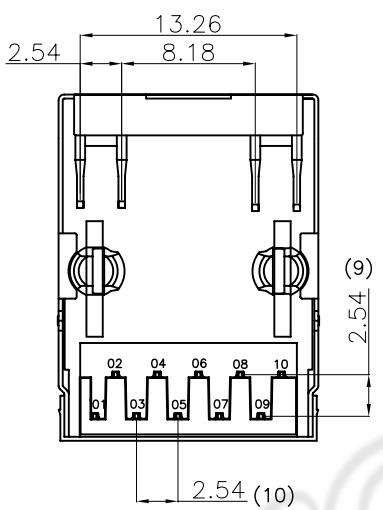
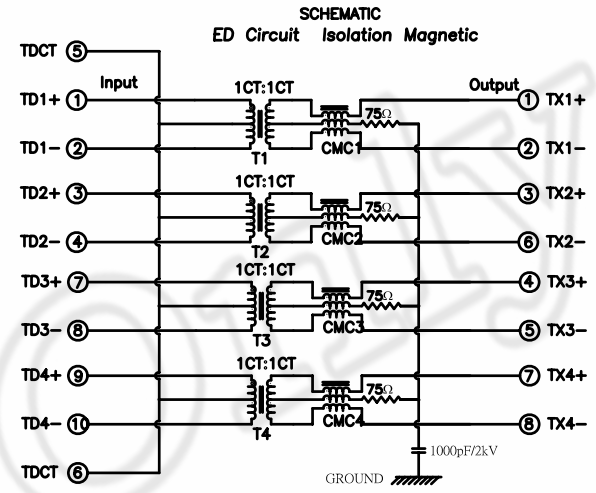
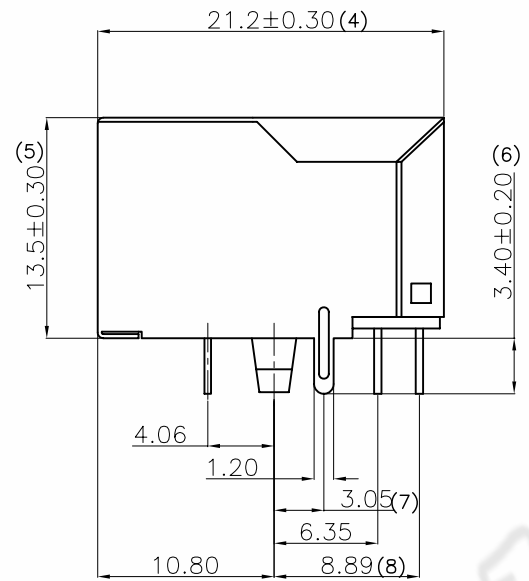
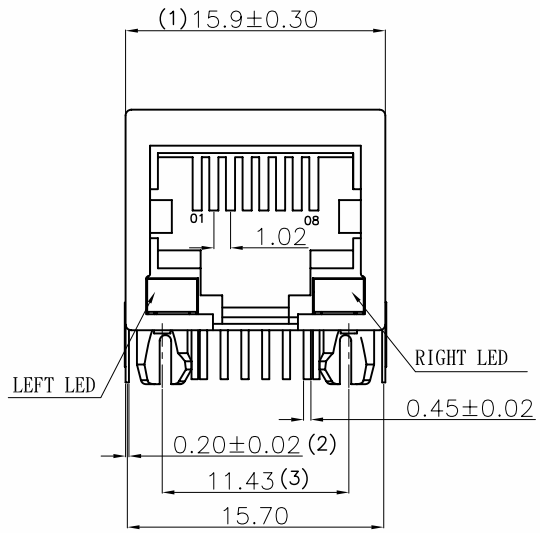
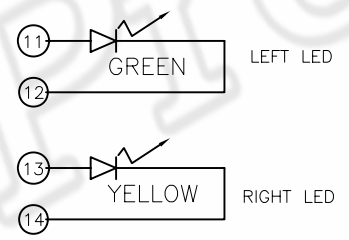

4. 12111-042ED020-35SR
- 環保標準: ROHS
 - 5: PA46, 黃色114C
 - 電鍍規格碼: 鍍半金6u"
 - 產品延伸碼
 - 腳后3.05
 - 產品彈片規格: 無彈片
 - 產品線路規格: ED線路
 - LED規格: 左綠右黃
 - 產品序列碼
 - 產品PORT數: 單PORT
 - 產品層數: 單層
 - 主結構碼: 扁針PORT口下階全包
 - RJ濾波器產品

NOTE 1:
1.MATERIALS:
HOUSING:THERMOPLASTIC POLYESTER, BLACK;
RJ CONTACT:PHOSPHOR BRONZE,T=0.35±0.02mm.
JOINT CONTACT:BRASS,T=0.30±0.02mm.
SHELL:BRASS,T=0.20±0.01mm.
2.PLATING:
RJ CONTACTS: SELECT GOLD PLATED OVER NICKEL UNDERPLATED OVERALL
JOINT CONTACTS: TIN PLATED OVER NICKEL UNDERPLATED OVERALL
SHELL: NICKEL UNDERPLATED OVERALL
3.SPECIFICATION:
OPERATING TEMPERATURE : 0°C~+70°C
STORAGE: -40°C~+85°C
DURABILITY: 750 CYCLES MIN
TYPE: BALANCE LOW PASS 100 IMPEDANCE
INSERTION LOSS: 1~100MHz-1.0dB MAX.
RETURN LOSS: 1~30MHz-18dB MIN.
30~60MHz-16dB MIN.
60~80MHz-12dB MIN.
80~100MHz-10dB MIN.
CROSS TALK: @1~100MHz-35dB MIN.
COMMON MODE REJECTION: @1~100 MHz-30dB MIN
INDUCTANCE AT 100KHz 100mV,8mA DC BIAS: 350uH MIN.
HI-POT: 1500Vrms (INPUT TO OUTPUT)

COMPLIANCE WITH THE REQUIEMENT RoHS HF SONY00259 OTHER
※ NO USING RESTRICTED AND BANNED SUBSTANCE

CUSTOMER DRAWING		LITE	Liteconn Co.,Ltd.					
-TOLERANCES- UNLESS OTHERWISE SPECIFIED				TITLE: RJ TRANSFORMER 1000M 單層PORT10P8(W/LED)燈腳平行式				
X.X	±0.35	X.X*		±3*	APPD:	DWG NO: 12111-042ED020-35SR		
X.XX	±0.25	X.XX*	±2*	CHECK:	DATE	SCALE	UNIT	PAGE
X.XXX	±0.15	X.XXX*	±1*	DRAW: Joe Chen	2011.11.18	1:1	MM	1/1